

YOUR PERFECT HAND TRUCK

Design Your Own Magliner

Mix and match parts from our modular components system for the customized hand truck to meet your needs.

Select from the components and accessories available.

Frame
C



+

Handle
11



+

Nose
AA



+

Wheel
815



+

Accessory
C5 Stair Climber



=

C11-AA-815-C5



Let Magliner Help Customize Your Hand Truck

FRAMES

ALL ALUMINUM



P/N	M/N	Ht.(in.)	WT.(lbs.)
30001	1	39	6.0

Straight back with 1-1/2" cross braces.



P/N	M/N	Ht.(in.)	WT.(lbs.)
303125	L	33	6.0
302553	C	39	6.5
300042	8	52	8.5

Straight back with 2-1/4" cross braces.

ALUMINUM WITH MOLDED CROSS BRACES



P/N	M/N	Ht.(in.)	WT.(lbs.)
303127	M	33	4.5
300010	4	39	5.0
303116	P	52	6.5

Straight back with 1-1/2" cross braces.



P/N	M/N	Ht.(in.)	WT.(lbs.)
303123	N	33	4.5
300021	S	39	5.0
303113	Q	52	7.0

Curved back with 1-1/2" cross braces.

VERTICAL STRAP OPTIONS



- Bolt-on vertical strap makes repair and in-field installation easy.
- Kits available for all frames.

P/N	WT.(lbs.)	WT.(lbs.)
30253	23	0.5
86300*	39	1.0
86351	39	1.0
86355	52	1.5

*NOTE: compatible with 30001 frame only.

P/N	WT.(lbs.)	WT.(lbs.)
86354	33	0.5
86352	39	1.0
86356	52	1.0

HANDLES

LOOP HANDLES



P/N	M/N	WT.(lbs.)
30100	11	1.0

Standard loop.



P/N	M/N	WT.(lbs.)
30108	12	1.5

Standard loop with universal brace.



P/N	M/N	WT.(lbs.)
30108	19	1.5

Standard loop with vinyl sleeve.



P/N	M/N	WT.(lbs.)
30108	22	2.0

Standard loop with vinyl sleeve and universal brace.

VERTICAL LOOP HANDLES



P/N	M/N	Ht.	WT.(lbs.)
30094	60	52	2.0
30095	60	60	3.5

Vertical loop for Hi-U extension for use with 1, 4, 8, C, L, M and P frames. 30095 for 5, N and Q frames.



P/N	M/N	Ht.	WT.(lbs.)
30098	15A	52	2.35
30099	15C	60	3.5
30090	15A	52	2.35
30097	15A	60	3.5

Vertical loop for use with 1, 4, 8, C, L, M and P frames. 30099 for 5, N and Q frames. 30097 for 5, N and Q frames.

SINGLE GRIP HANDLES



P/N	M/N	WT.(lbs.)
301126	13B	5.5
301127	13C	6.0

Welded pistol grip.



P/N	M/N	WT.(lbs.)
30104	17	2.0

Welded pistol grip.

DOUBLE GRIP HANDLES



P/N	M/N	WT.(lbs.)
86031	16	2.0

Bolted double pistol grip handle with universal brace.



P/N	M/N	WT.(lbs.)
301137	30	2.5

Welded double grip.

DOUBLE LOOP HANDLES



P/N	M/N	WT.(lbs.)
301115	25B	5.0
301119	25C	6.0

Welded double loop.



P/N	M/N	WT.(lbs.)
302297	35B	6.0
302298	35D	6.2

Welded double loop.

NOSES

DIE CAST



ALUMINUM				
P/N	M/N	W"	D"	WT.(lbs.)
300200	AA	14	7-1/2	4.0
300201	UA	18	7-1/2	5.0

MAGNESIUM				
P/N	M/N	W"	D"	WT.(lbs.)
300204	AM	14	7-1/2	2.5
300197	HM	14	12	3.0
300205	UM	18	7-1/2	3.0

EXTRUDED ALUMINUM



P/N	M/N	W"	FLUSH MOUNT D"	RECESSED MOUNT D"	WT.(lbs.)
300244	E1	14	9	7-1/8	4.5
300254	E2	14	9	N/A	5.0
300245	G1	18	9	7-1/8	5.5
300248	G2	18	9	N/A	6.0
300203	K1	16	12	N/A	7.0
300215	K2	20	12	N/A	8.5

*Recessed mount not available on narrow-aisle models.

STEEL

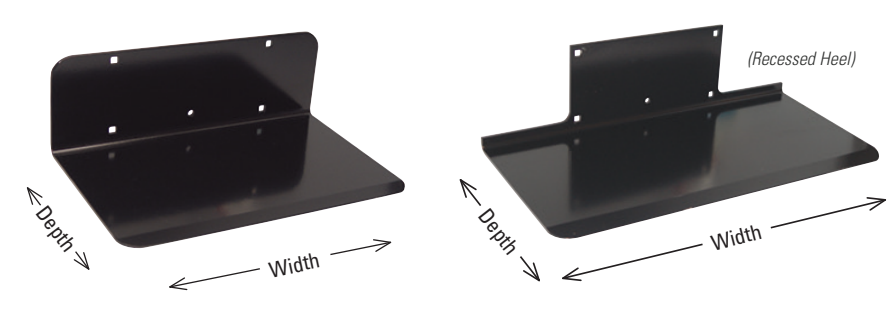

P/N	M/N	W"	FLUSH MOUNT D"	RECESSED MOUNT D"	WT.(lbs.)
300544	E3	14	9	7-1/8	9.5
300554	E4	14	9	N/A	10.5
300545	G3	18	9	7-1/8	11.5
300548	G4	18	9	N/A	13.5

WHEELS

MICROCELLULAR



P/N	M/N	D"	WT.(lbs.)
131010	1010	10	4.0

Puncture resistant, non-marking, tire on one-piece steel hub with semi-precision bearings.



P/N	M/N	D"	WT.(lbs.)
111070	1070	10	2.5

Puncture resistant, non-marking, microcellular tire on one-piece high-density, interlocking polyethylene hub with semi-precision bearings.



P/N	M/N	D"	WT.(lbs.)
111075	1075	10	3.0

Puncture resistant, non-marking, microcellular tire on one-piece high-density, interlocking polyethylene hub with semi-precision bearings.



P/N	M/N	D"	WT.(lbs.)
111080	1080	10	4

Puncture resistant, non-marking, microcellular tire on one-piece high-density, interlocking polyethylene hub with semi-precision bearings.

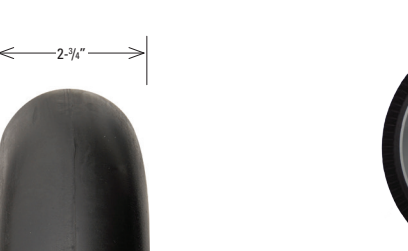

P/N	M/N	D"	WT.(lbs.)
111025	F2	12	3.5

Flow through design interlocks rubber, preventing run-off and scuffing. (111070, 111075 and 111080 wheels)

PNEUMATIC



P/N	M/N	D"	WT.(lbs.)
121060	1060	10	4.5

4-ply tube-type tire with three-piece off-set hub and semi-precision bearings.



P/N	M/N	D"	WT.(lbs.)
101020	1020	10	7.0

Foam filled with three-piece off-set hub and semi-precision bearings.

SOLID RUBBER

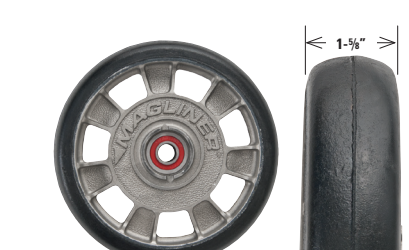

P/N	M/N	D"	WT.(lbs.)
10815	815	8	2.5

Mold-on rubber on die-cast hub with semi-precision bearings.



P/N	M/N	D"	WT.(lbs.)
11825	825	8	3.5
111025	1025	10	5.5

Puncture resistant, solid rubber tire on one-piece polyolefin hub with semi-precision bearings.

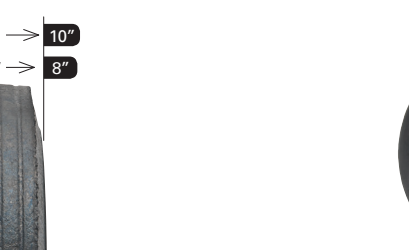

P/N	M/N	D"	WT.(lbs.)
10830	830	8	2.0
101030	1030	10	3.0

Puncture resistant, non-marking balloon cushion rubber on one-piece polyolefin hub with semi-precision bearings.

ACCESSORIES



P/N	L"	W"	WT.(lbs.)
302580	13	8	0.5

- Main pocket 13" long x 8" wide x 2" deep with 1 Velcro strap
- Outside pocket 5 1/4" long x 5 1/2" wide

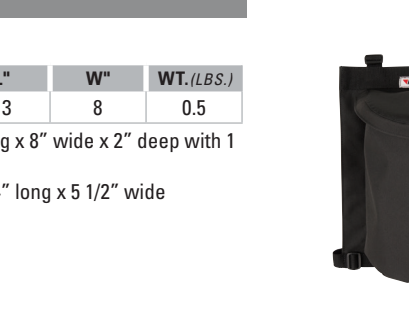

P/N	L"	W"	WT.(lbs.)
302582	12-1/2	12	1.0

- 1 pocket 11" deep x 9" wide



P/N	L"	W"	WT.(lbs.)
302681	16-1/2	12	1.0

- 2 top pockets, sealed with Velcro 10" long x 6" wide
- 1 tool pocket 12" wide x 3 1/2" deep



P/N	L"	W"	WT.(lbs.)
302683	29	12	1.0

- 2 top pockets, sealed with Velcro 10 1/2" long x 6" wide
- 1 tool pocket 12" wide x 3 1/2" deep
- 1 pocket 11 1/2" wide x 12" deep

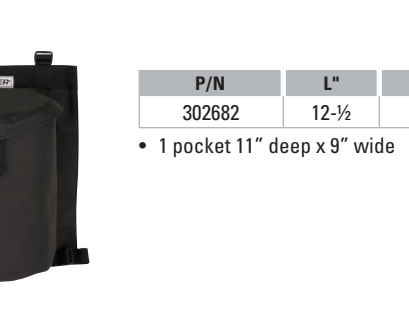

P/N	L"	W"	WT.(lbs.)
301019	F1	4.0	

24" length x 12" wide low-profile formed plate extension.

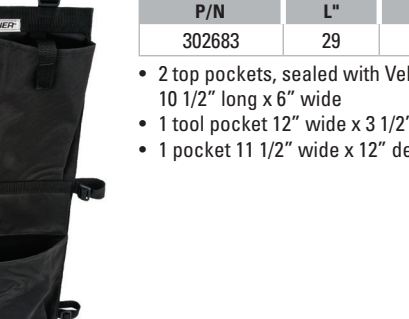

P/N	M/N	WT.(lbs.)
301026	F3	4.5

30" length x 12" wide extruded aluminum channel extension.



P/N	L"	WT.(lbs.)
32511	4	1.5

Sliding leg hook swings out of the way when not in use. 4" hook for straight side kegs and 5" hook for barrel-style kegs. For use with 300051 frame only (rod and hardware required).

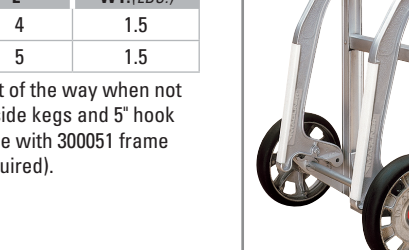

P/N	WT.(lbs.)
86006	2.5

Cast aluminum sliders with replaceable low-friction polymer skid bars. Tough and quiet (narrow aisle use 86002).

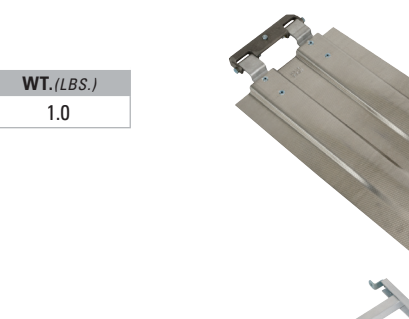

P/N	M/N	WT.(lbs.)
30112K		0.5

Holds keg in place securely. For use with 30021 frame only.

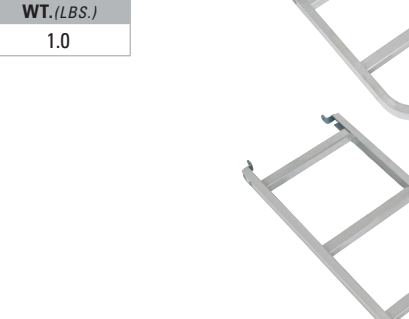

P/N	M/N	WT.(lbs.)
30114K		1.5

Wheel guards prevent loads from rubbing against hand truck wheels.

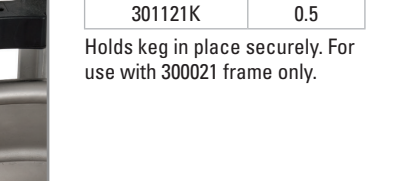

P/N	H"	W"	WT.(lbs.)
30114K	8-1/2	2-1/2	1.5

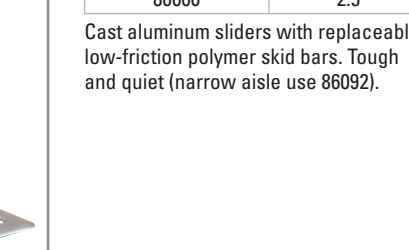

P/N	H"	W"	WT.(lbs.)
30114K	8-1/2	2-1/2	1.5

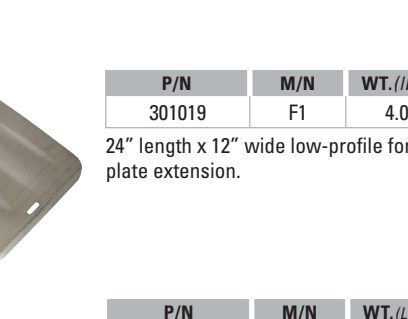

P/N	M/N	WT.(lbs.)
30114K		1.5

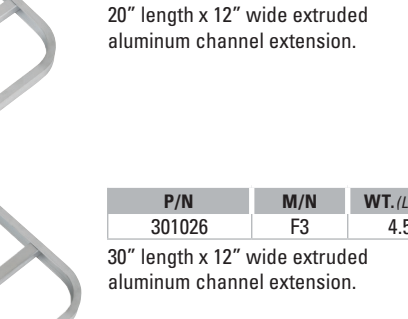

P/N	M/N	WT.(lbs.)
30114K		1.5



P/N	M/N	WT.(lbs.)
30114K		1.5